

S
S6
 5.5

5.5 TONNE



Mobile Vehicle Lifts

The S6 5.5 heavy duty mobile vehicle lift is part of the market leading S6 range.

SOMERSTOTALKARE are the pioneers of heavy duty mobile vehicle lifts and have supplied more than 6000 sets of mobile vehicle lifts in the UK.

The S6 5.5 Heavy Duty Mobile Lifts are manufactured to BS EN 1493 - 1999

FEATURES

Columns have light weight column design

Columns have simple operating System

Wireless Controller Area Network (CAN) System

Fully compliant to Health & Safety requirements

Universal Columns allow for ease of multiple applications



5.5 TONNE SPECIFICATION

S6^{5.5}

www.stkare.co.uk

- Automatic synchronisation and communication between columns
- Electronic measurement by inductive sensors
- Electronic shutdown if obstruction detected
- Easy handling ensured by slim design and low column weight (400kg)
- Quick and easy interconnections of columns
- Independent safety nut
- Special design lifts available for forklifts and other special vehicle applications
- CE design certification

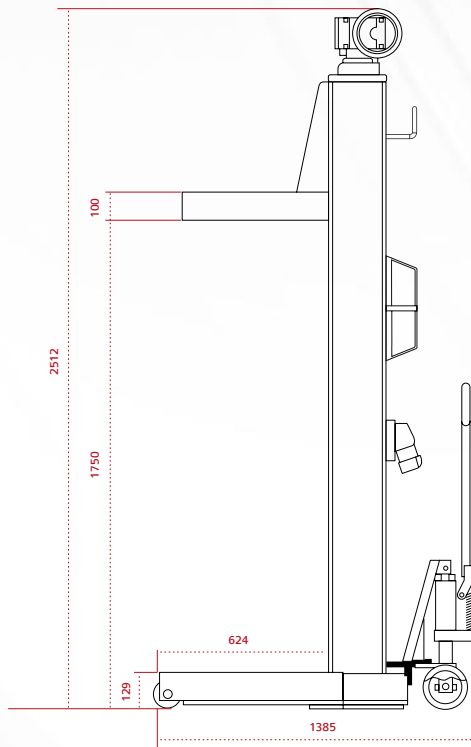
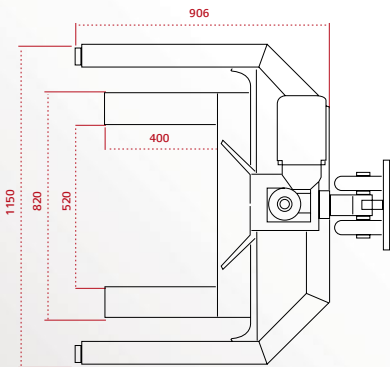

Please Note:
Diagrams are provided for illustrative purposes only. Specifications are subject to change without prior notice.

Load capacity per column:	5,500kg
Net weight per column:	400kg
Raising/lowering time:	150s
Motor power per column:	2.2kw
Control voltage:	220 / 24V
Supply voltage:	3~400 V+N+PE; 50Hz
System of protection:	IP54

- **Try before you buy**
- **24hr Service Hotline**

SOMERSTOTALKARE

**Web: www.stkare.co.uk Email: sales@stkare.co.uk
Tel: 0121 585 2724 Fax: 0121 585 2725**