

**SOMERSTOTALKARE**

S6cf

7.5 TONNE



## Cable Free Mobile Vehicle Lifts

The S6cf Cable Free mobile vehicle lifts offer unrivalled levels of practicality and manoeuvrability.

The S6cf Heavy Duty Mobile Lifts are manufactured to BS EN 1493 - 1999

### FEATURES

Increased level of manoeuvrability

Ideally suited for applications where 3 phase mains supply is not available

Can be charged from a Single Phase 230v Power Supply

No Cables!



# CABLE FREE

## 7.5 TONNE SPECIFICATION

# S6<sup>cf</sup>

www.stkare.co.uk

S6cf (Cable Free)

- Universal Cable Free Columns allow for ease of multiple applications
- Radio synchronisation and communication between columns
- Can be charged from single phase 230v power supply
- Recirculating ball nut and screw (efficiency over 90%)
- Electronic measurement by inductive sensors
- Electronic shutdown if obstruction detected
- Easy handling ensured by slim design and low column weight (490kg)
- Independent locking safety device
- Special design lifts available for forklifts and other special vehicle applications
- Customised system available on request
- CE design certification

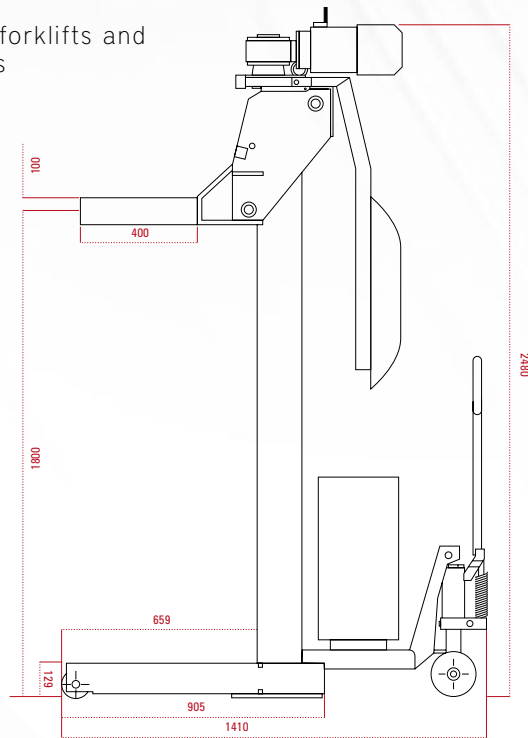
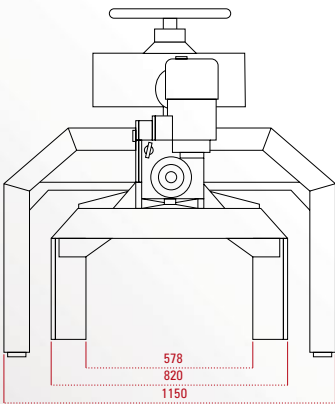

Please Note:  
Diagrams are provided for illustrative purposes only. Specifications are subject to change without prior notice.

Load capacity per column:	7,500kg
Net weight per column:	490kg
Raising/lowering time:	113s
Motor power per column:	1.5kw
Control voltage:	48v
Supply voltage:	230 V+N+PE; 50Hz
System of protection:	IP54

## LIFTING SYSTEM

Hardened stainless steel screw with low friction recirculating ball nut. Splash proof and dirt repellent design giving long life and low maintenance.

Independent locking device acting directly between column and carriage.



Lifting System

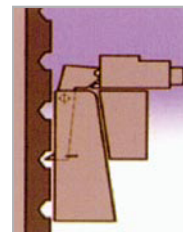

Locking Device

- **Lifetime Warranty\***
- **Try before you buy**
- **24hr Service Hotline**

\*Terms and conditions apply

**SOMERSTOTALKARE**

Web: [www.stkare.co.uk](http://www.stkare.co.uk) Email: [sales@stkare.co.uk](mailto:sales@stkare.co.uk)  
Tel: 0121 585 2724 Fax: 0121 585 2725